

Layout

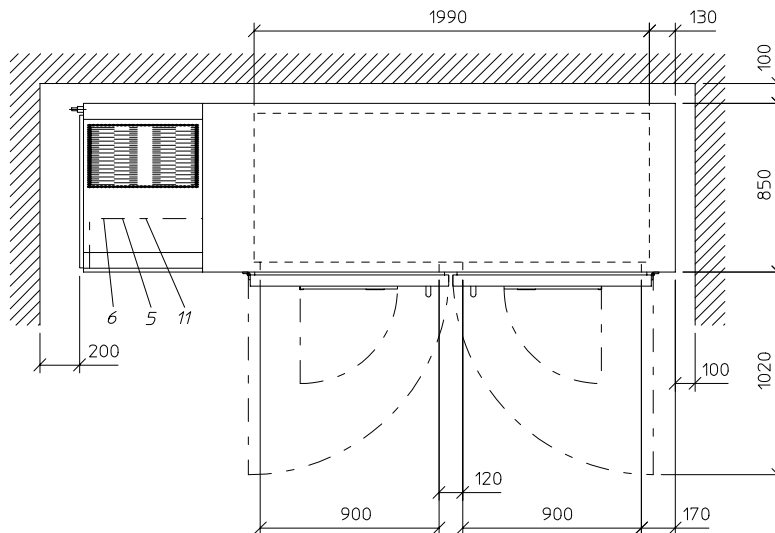
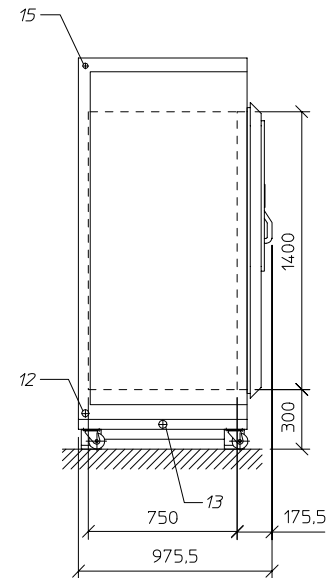
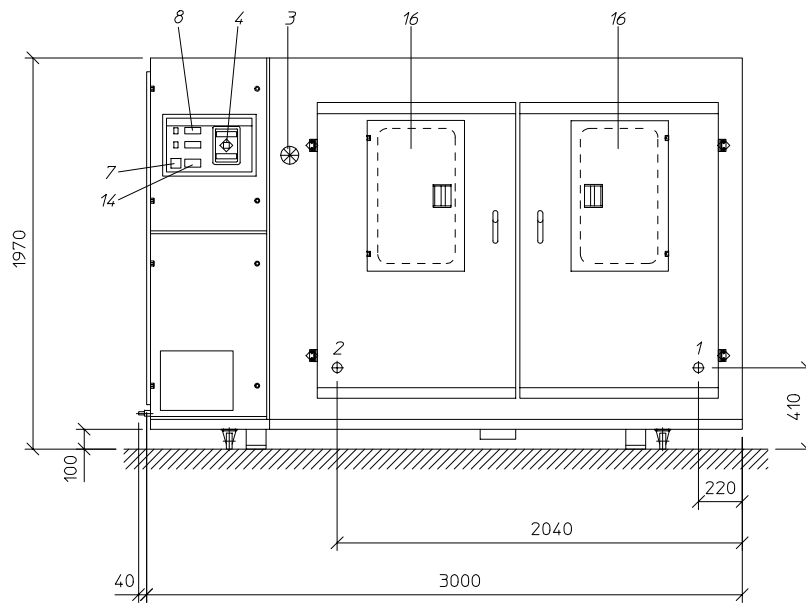

- 1, 2 Entry port Ø 50 mm*
- 3 Fresh air
- 4 E4-Terminal
- 5 Interface RS 232
- 6 Potential-free contact
- 7 Main switch

- 8 Adjustable operating temperature limiter*
- 9 Not assigned
- 10 Not assigned
- 11 Connector panel*
- 12 Connection for humidification water
- 13 Drain for test space and humidification water
- 14 Rating plate
- 15 Mains connection, cable-length approx. 3.5 m
- 16 Door with window
- 17 Not assigned
- 18 Not assigned

+ For narrow entry openings components (e.g. hinges) may be screwed off to minimize width.

* optional accessory